



EN Operating instructions..... pages 1 to 6
Translation of the original operating instructions

FR Vous trouverez la version actuelle du mode d'emploi dans votre langue nationale officielle sur l'Internet, www.schmersal.net.

ES Encontrará el manual de instrucciones actual en su idioma oficial de la UE en nuestra página de Internet www.schmersal.net.

NL U vindt de huidige versie van de gebruikshandleiding in uw officiële landstaal op het Internet, www.schmersal.net.

IT Il manuale d'istruzioni aggiornato nella vostra lingua (lingua ufficiale UE) è scaricabile in Internet all'indirizzo www.schmersal.net.

JP EU公用語で書かれた最新の取扱説明書は、インターネット(www.schmersal.net)からダウンロードできます。

Content

1 About this document	
1.1 Function	1
1.2 Target group: authorised qualified personnel.....	1
1.3 Explanation of the symbols used	1
1.4 Appropriate use	1
1.5 General safety instructions	1
1.6 Warning about misuse	2
1.7 Exclusion of liability	2
2 Product description	
2.1 Ordering code	2
2.2 Special versions.....	2
2.3 Destination and use	2
2.4 Technical data	2
2.5 Safety classification	2
3 Mounting	
3.1 General mounting instructions	3
3.2 Dimensions	3
3.3 Axial misalignment	3
3.4 Adjustment.....	3
4 Electrical connection	
4.1 General information for electrical connection.....	4
5 Configuration	
5.1 Programming the slave address	4
5.2 Configuration of the safety monitor	4
6 Set-up and maintenance	
6.1 Functional testing.....	4
6.2 Maintenance	4
7 Disassembly and disposal	
7.1 Disassembly.....	4
7.2 Disposal	4
8 Appendix	
8.1 EC Declaration of conformity	5

1 About this document

1.1 Function

This operating instructions manual provides all the information you need for the mounting, set-up and commissioning to ensure the safe operation and disassembly of the safety switchgear. The operating instructions must be available in a legible condition and a complete version in the vicinity of the device.

1.2 Target group: authorised qualified personnel

All operations described in this operating instructions manual must be carried out by trained specialist personnel, authorised by the plant operator only.

Please make sure that you have read and understood these operating instructions and that you know all applicable legislations regarding occupational safety and accident prevention prior to installation and putting the component into operation.

The machine builder must carefully select the harmonised standards to be complied with as well as other technical specifications for the selection, mounting and integration of the components.

1.3 Explanation of the symbols used



Information, hint, note:

This symbol is used for identifying useful additional information.



Caution: Failure to comply with this warning notice could lead to failures or malfunctions.

Warning: Failure to comply with this warning notice could lead to physical injury and/or damage to the machine.

1.4 Appropriate use

The products described in these operating instructions are developed to execute safety-related functions as part of an entire plant or machine. It is the responsibility of the manufacturer of a machine or plant to ensure the proper functionality of the entire machinery or plant.

The safety switchgear must be exclusively used in accordance with the versions listed below or for the applications authorised by the manufacturer. Detailed information regarding the range of applications can be found in the chapter "Product description".

1.5 General safety instructions

The user must observe the safety instructions in this operating instructions manual, the country-specific installation standards as well as all prevailing safety regulations and accident prevention rules.



Further technical information can be found in the Schmersal catalogues or in the online catalogue on the Internet: www.schmersal.net.

The information contained in this operating instructions manual is provided without liability. Subject to technical modifications.

There are no residual risks, provided that the safety instructions as well as the instructions regarding mounting, commissioning, operation and maintenance are observed.

1.6 Warning about misuse



In case of inadequate or improper use or manipulations of the safety switchgear, personal hazards or damage to machinery or plant components cannot be excluded. The relevant requirements of the standard EN 1088 must be observed.

1.7 Exclusion of liability

We shall accept no liability for damages and malfunctions resulting from defective mounting or failure to comply with this operating instructions manual. The manufacturer shall accept no liability for damages resulting from the use of unauthorised spare parts or accessories.

For safety reasons, invasive work on the device as well as arbitrary repairs, conversions and modifications to the device are strictly forbidden; the manufacturer shall accept no liability for damages resulting from such invasive work, arbitrary repairs, conversions and/or modifications to the device.

2 Product description

2.1 Ordering code

This operating instructions manual applies to the following types:

BNS 260 ①-AS-②		
No.	Option	Description
①		Connecting cable (2 m)
	STG	Connecting cable with M12 connector (straight):
	STW	Connecting cable with M12 connector (angled):
②	L	Door hinge on the left-hand side
	R	Door hinge on the right-hand side
Actuator		
	BPS 260 -1	Standard
	BPS 260 -2	Mounting angle 90°

2.2 Special versions

For special versions, which are not listed in the order code below 2.1, these specifications apply accordingly, provided that they correspond to the standard version.

2.3 Destination and use

The BNS 260 AS safety sensor is used in AS-Interface systems (to EN 50295) for monitoring the position of movable safety guards to EN 1088. The combination of the BNS 260 AS safety sensor, the BPS 260-1/-2 actuator and the ASM safety monitor ensures the safe monitoring of the condition of the corresponding safety guard. To actuate the BNS 260 AS safety sensor, only the coded BPS 260-1/-2 actuators must be used.

The safety function of the BNS 260 AS consists in safely switching off the code transmission when the safety guard is opened and maintaining the safe switched off condition for as long as the safety guard is open.

An AS-Interface Safety at Work component functions on the basis of an individual code generator (8 x 4 bit). This safety code is cyclically transmitted over the AS-i network and monitored by the ASM safety monitor.

The component status can be evaluated through a PLC with AS-Interface master. The safety-related functions are enabled by means of the AS-i safety monitor.

LED indication

The LED's have the following meaning (to EN 50295):

Green LED	AS-Interface supply voltage
Red LED	AS-Interface communication error or slave address = 0



The user must evaluate and design the safety chain in accordance with the relevant standards and the required safety level.

2.4 Technical data

Standards:	EN 50295, IEC 60947-5-3, EN ISO 13849-1, IEC 61508
Enclosure:	glass-fibre reinforced thermoplastic, self-extinguishing
assured switching distance	5 mm
S _{ao} :	
assured switch-off distance	15 mm
S _{ar} :	
Protection class:	IP 67 to IEC/EN 60529
Termination:	LSYY cable (0.23 mm ² / AWG 24); M12 x 1 connector, 4-pole
Ambient temperature:	- 25 °C ... + 60 °C
Storage and transport temperature:	- 25 °C ... + 70 °C
Switching frequency:	≤ 1 Hz
Electrical data AS-Interface:	
AS-I voltage range:	26.5...31.6 VDC, through AS-Interface, reverse polarity-proof
AS-I power consumption:	≤ 0.05 A
AS-I specification: (V 2.1)	AS-i slave profile: S-0.B.E, IO-Code: 0x0, ID-Code: 0xB, ID-Code1: 0xF, ID-Code2: 0xE
AS-interface inputs:	Contact 1: Data bits D0 / D1 = static 00 or dynamic code transmission Contact 2: Data bits D2 / D3 = static 00 or dynamic code transmission
Parameter port:	P0 ... P3: no function, set parameter outputs to "1111" (0xF)
Input module address:	preset to address 0, can be changed through AS-interface bus master or hand-held programming device
Diagnostic display:	AS-i LED green AS-Interface supply voltage AS-i LED red AS-Interface communication error or slave address = 0

2.5 Safety classification (Approval under preparation)

Standards:	EN ISO 13849-1, IEC 61508
PL:	up to e
Control category:	up to 4
PFH value:	6.21 x 10 ⁻⁹ / h for ≤ 500,000 operations / year
SIL:	up to 3
Service life:	20 years

3 Mounting

3.1 General mounting instructions

- Fitting is only authorised in a de-energised condition
- Do not use the sensor and the actuator as a mechanical backstop.
- Any mounting position, provided that the active surfaces are opposite
- Inseparably fix the sensor and the actuator to the safety guard
- Exclusively mount the safety sensor on flat surfaces to avoid tensile stresses that could damage the sensor or lead to varying switching distances
- Do not install the safety sensor and the actuator in strong magnetic fields
- If possible, do not mount the sensor and the actuator on ferromagnetic material. A non-magnetic spacer of at least 5 mm thick or the original spacer must be used. The use of non-magnetic fixing screws is recommended as well.
- Do not subject the safety sensor and actuator to extreme vibrations and shocks.
- Keep away from metal chips
- The mounting distance between two sensors should always be at least 50 mm



Please observe the remarks of the standards EN ISO 12100, EN 953 and EN 1088.

3.2 Dimensions

All measurements in mm.

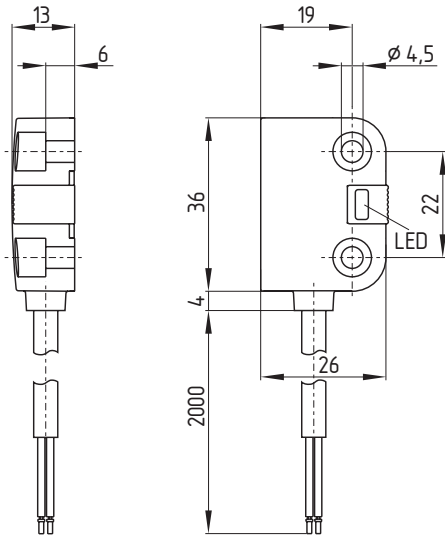

BNS 260 AS safety sensor

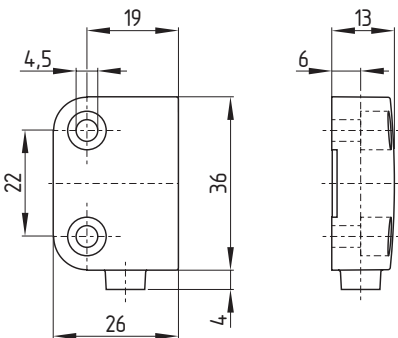

BPS 260-1/-2 actuator

3.3 Axial misalignment

A horizontal and vertical misalignment of the safety sensor and the actuator is tolerated. The possible misalignment depends on the distance of the active surface of the sensor and the actuator. The sensor remains active within the tolerance range.

The specified switching distances refer to oppositely mounted safety sensors and actuators.

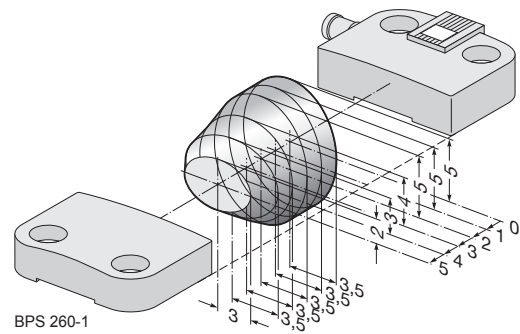

BPS 260-1

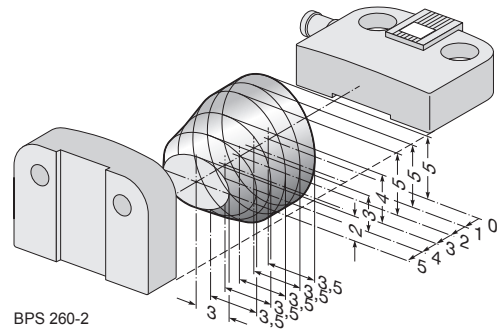

BPS 260-2

3.4 Adjustment

Adjust the safety sensor and the actuator to the safety guard. The proper functionality of both safety channels must be checked by means of the connected safety-monitoring module.

4 Electrical connection

4.1 General information for electrical connection



The electrical connection may only be carried out by authorised personnel in a de-energised condition.

The connection to the AS-Interface system is realised through the open cable extremity or an M12 connector. The wiring configuration of the M12 connector (to EN 50295) is defined in the following way:

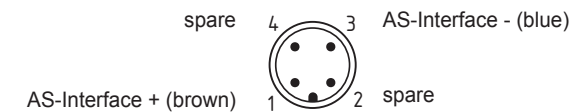

5 Configuration

5.1 Programming the slave address

The slave address is programmed through the connecting cable of the BNS 260 AS. Depending on the variant used, every address can be programmed between 1 and 31 through an M12 connector or an open cable extremity.

5.2 Configuration of the safety monitor

The BNS 260 AS must be configured in the ASM safety monitor as dual-channel dependent module with start-up test.

The BNS 260 AS can be configured in the ASIMON configuration software with the following safety monitors (also refer to the ASIMON manual):

Dual-channel dependent

- With startup test
- Synchronisation time typically 0.5 – 2.0 s

Dual-channel dependent with filtering

The use of this safety-monitoring module is especially advantageous on safety guards bouncing or vibration against the mechanical stop upon closing.

- With startup test
- Stabilising time typically 0.5 -1.0 s
- Synchronisation time typically 5.0 – 10.0 s

The safety-monitoring module is only released after expiration of the stabilising time; the synchronization time always must exceed the stabilising time.



The configuration of the safety monitor must be tested and confirmed by a qualified and authorised safety expert/safety engineer.



During the project planning, it must be observed that the length of the cable of each individual safety sensor is integrated in the overall length (max. 100 m without repeater) of the AS-Interface network

6 Set-up and maintenance

6.1 Functional testing

The safety function of the safety components must be tested. The following conditions must be previously checked and met:

1. Check the switch enclosure for damage.
2. Fitting and integrity of the cable connections
3. Connect the BNS 260 AS to the AS-Interface network
4. Set the parameter outputs to "1111" (0xF)
5. Check the correct function of the BNS and BPS system with configured ASM safety monitor

6.2 Maintenance

In case of correct fitting in accordance with the above-described instructions, the BNS 260 requires little maintenance. A regular visual inspection and functional test, including the following steps, is recommended:

1. Remove particles of dust and soiling
2. Fitting and integrity of the cable connections

Damaged or defective components must be replaced.

7 Disassembly and disposal



7.1 Disassembly

The safety switchgear must be disassembled in a de-energised condition only.

7.2 Disposal

The safety switchgear must be disposed of in an appropriate manner in accordance with the national prescriptions and legislations.

8.1 EC Declaration of conformity

	
<h2>EC Declaration of conformity</h2>	
Translation of the original declaration of conformity valid as of December 29, 2009	K.A. Schmersal GmbH Industrielle Sicherheitssysteme Mödinghofe 30, D - 42279 Wuppertal Germany Internet: www.schmersal.com
We hereby certify that the hereafter described safety components both in its basic design and construction conforms to the applicable European Directives.	
Name of the safety component / type:	BNS 260 AS
Description of the safety component:	Coded safety sensor with magnetic operating principle with integrated AS-i Safety at Work
Harmonised EC-Directives:	2006/42/EC EC-Machinery Directive 2004/108/ EC EMC-Directive
Person authorized for the compilation of the technical documentation:	Ulrich Loss Mödinghofe 30 42279 Wuppertal
Place and date of issue:	Wuppertal, November 16, 2009
BNS 260 AS-B-DE	
	Authorised signature Heinz Schmersal Managing Director



Note

The currently valid declaration of conformity can be downloaded from the internet at www.schmersal.net.



K. A. Schmersal GmbH
Industrielle Sicherheitssysteme
Möddinghofe 30, D - 42279 Wuppertal
Postfach 24 02 63, D - 42232 Wuppertal

Telefon +49 - (0)2 02 - 64 74 - 0
Telefax +49 - (0)2 02 - 64 74 - 1 00
E-Mail: info@schmersal.com
Internet: <http://www.schmersal.com>